



The Good, the Bad, and the Really Ugly: DSNZPARM

William Favero
Senior Certified IT Specialist
DB2 for z/OS Software Sales Specialist
IBM Sales and Distribution
West Region, Americas

wfavero@attglobal.net

Copyright © 2005 IBM Corporation
All rights reserved

Session Objectives

- After completing this session, you should be able to:
 - Explain the purpose of DSNZPARM
 - Describe DB2 SET SYSPARM Command
 - Describe each of the macros and their major keywords
 - Describe the different ?type? of DSNZPARMs
 - Advise on how best to use DSNZPARMs



You're right...

Way too many foils!!!!



There is so much good stuff, I just couldn't decide what to leave out.

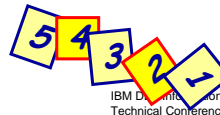

Slide 3 of 80

Copyright © 2005 IBM Corporation
All rights reserved

IBM DB2 Information Management
Technical Conference

Shameless Self-promotion

- DB2 blog
<http://blogs.ittoolbox.com/database/db2zos/>
- The text for THIS presentation
 - **zJournal**
 - April/May 2005 issue
 - “The Good, the Bad, and the Really Ugly: DB2's DSNZPARM Module”
 - August/September 2005 issue
 - “Just the Good This Time: More DB2 DSNZPARM Keywords”

Both available at <http://www.zjournal.com/>

Slide 4 of 80

Copyright © 2005 IBM Corporation
All rights reserved

IBM DB2 Information Management
Technical Conference

Agenda

- What is DSNZPARM
- The Macros
- How do you change DSNZPARM
- Dynamically reloading DSNZPARM
- What's meant by hidden, opaque and visible?
- Some DSNZPARM keywords

Slide 5 of 80

Copyright © 2005 IBM Corporation
All rights reserved

IBM DB2 Information Management
Technical Conference

So, What's in a Title

- The Good
 - Actually, DSNZPARM is a good thing getting better and more helpful with each version of DB2
- The Bad
 - Bad, as in Very Cool... it's amazing what can be accomplished if you are comfortable working with your DSNZPARMs
- And the Really Ugly
 - Ugly only if you start touching things you shouldn't be touching

Slide 6 of 80

Copyright © 2005 IBM Corporation
All rights reserved

IBM DB2 Information Management
Technical Conference

What are DSNZPARMs

- Data only, subsystem parameter load module containing the DB2 execution-time parameters
- Initially set at install time through the installation ISPF panels
- Includes macros:
 - DSN6ARVP – Archive dataset parameters
 - DSN6ENV – DB2 environment settings
 - DSN6FAC – DDF
 - DSN6LOGP – Log stuff
 - DSN6SPRM – Initialization parameters for DBM1
 - DSN6SYSP – Miscellaneous system parameters
 - DSN6GRP – Group stuff for data sharing

Slide 7 of 80

Copyright © 2005 IBM Corporation
All rights reserved

IBM DB2 Information Management
Technical Conference

Install ≠ DSNZPARM

- Some DSNZPARMs are set outside the install panels
 - Hidden – discussed later
 - Opaque – discussed later
- Some install panels do not update DSNZPARMs
 - IRLM start procedure
 - DSNHDECP
 - i.e. – data and time formats
 - Etc...

Slide 8 of 80

Copyright © 2005 IBM Corporation
All rights reserved

IBM DB2 Information Management
Technical Conference

Changing Your DSNZPARMs

Edit parameter list, assemble, link and restart DB2

Changing Your DSNZPARMs

~~Edit parameter list, assemble, link and restart DB2~~
Not Any More

Changing Your DSNZPARMs

Edit parameter list, assemble, link and restart DB2

Change your DSNZPARMs online

Changing Your DSNZPARMs

Edit parameter list, assemble, link and restart DB2

~~Change your DSNZPARMs online~~

Not Exactly

Changing Your DSNZPARMs

Edit parameter list, assemble, link and restart DB2

Change your DSNZPARMs online

Change some of your DSNZPARMs online

Slide 13 of 80

Copyright © 2005 IBM Corporation
All rights reserved

IBM DB2 Information Management
Technical Conference

Changing Your DSNZPARMs

Edit parameter list, assemble, link and restart DB2

Change your DSNZPARMs online

Change some of your DSNZPARMs online

Not Quite

Slide 14 of 80

Copyright © 2005 IBM Corporation
All rights reserved

IBM DB2 Information Management
Technical Conference

Changing Your DSNZPARMs

Edit parameter list, assemble, link and restart DB2

Change your DSNZPARMs online

Change some of your DSNZPARMs online

**Change DSNZPARM parameters and
dynamically load LOAD module into storage**

Slide 15 of 80

Copyright © 2005 IBM Corporation
All rights reserved

IBM DB2 Information Management
Technical Conference

Changing Your DSNZPARMs

Edit parameter list, assemble, link and restart DB2

Change your DSNZPARMs online

Change some of your DSNZPARMs online

**Change DSNZPARM parameters and
dynamically load LOAD module into storage**



Slide 16 of 80

Copyright © 2005 IBM Corporation
All rights reserved

IBM DB2 Information Management
Technical Conference

-SET SYSPARM

- Dynamically change selected DSNZPARM values
 - Prior to Version 7, required recycle of DB2
 - Still requires the first steps of DSNTIJJZ to be executed
 - Change macro parameters
 - Assemble macros
 - Link
 - Now you should use the
 - -SET SYSPARM command

Slide 17 of 80

Copyright © 2005 IBM Corporation
All rights reserved

IBM DB2 Information Management
Technical Conference

-SET SYSPARM

- Load/Reload new DSNZPARM member
 - Either SYSOPR, SYSCTRL or SYSADM must be in privilege set of auth-id issuing command
- Works only at data sharing member level
 - Each member has its own DSNZPARM load module
- Cannot change individual parameters
- Not all parameters are eligible for change
- Not all changes are immediate

Slide 18 of 80

Copyright © 2005 IBM Corporation
All rights reserved

IBM DB2 Information Management
Technical Conference

-SET SYSPARM

```
-SET SYSPARM
  LOAD
    (
      DSNZPARM
      Module name
    )
  RELOAD
  STARTUP
```

Slide 19 of 80

Copyright © 2005 IBM Corporation
All rights reserved

IBM DB2 Information Management
Technical Conference

-SET SYSPARM

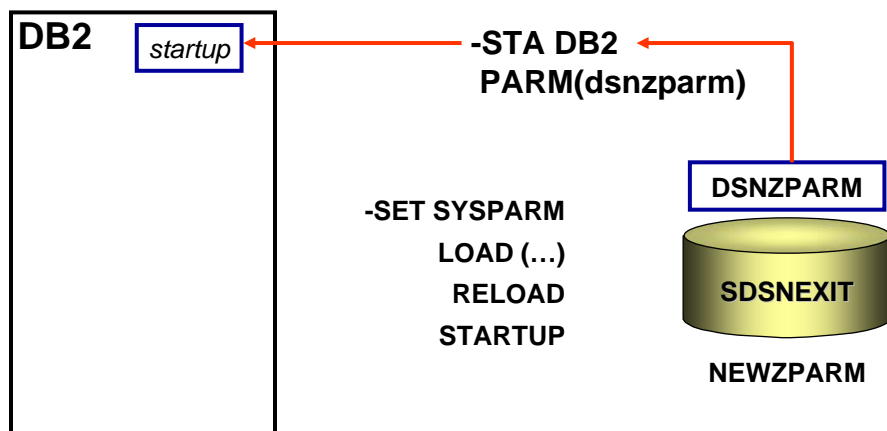

Slide 20 of 80

Copyright © 2005 IBM Corporation
All rights reserved

IBM DB2 Information Management
Technical Conference

-SET SYSPARM

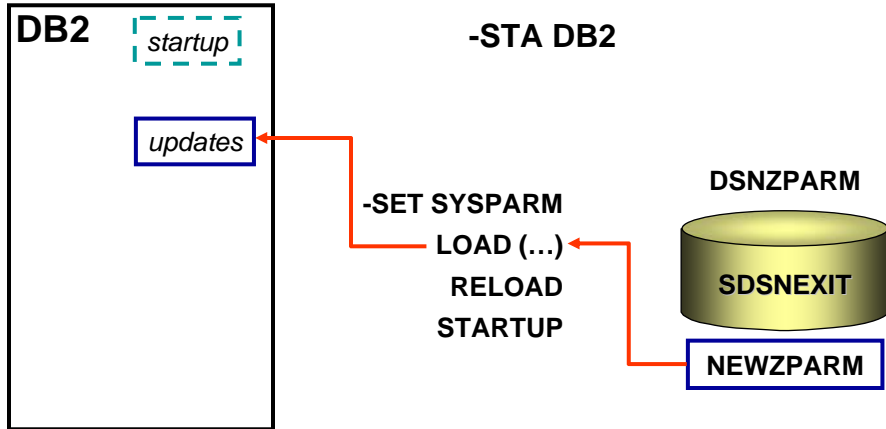

Slide 21 of 80

Copyright © 2005 IBM Corporation
All rights reserved

IBM DB2 Information Management
Technical Conference

-SET SYSPARM

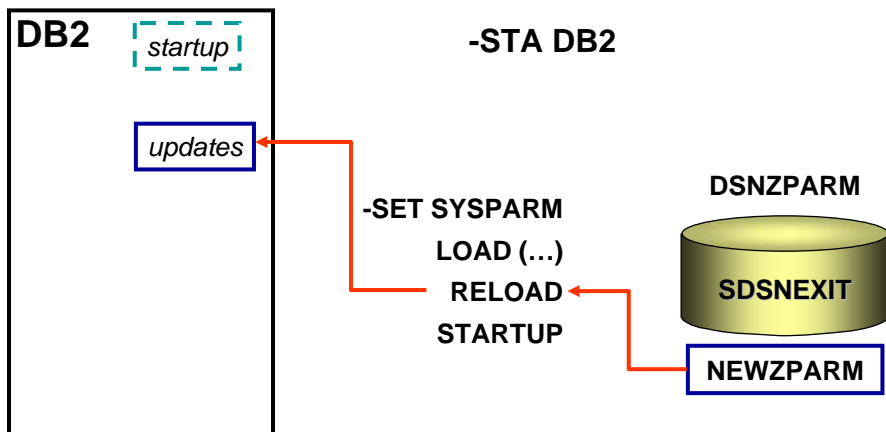

Slide 22 of 80

Copyright © 2005 IBM Corporation
All rights reserved

IBM DB2 Information Management
Technical Conference

-SET SYSPARM

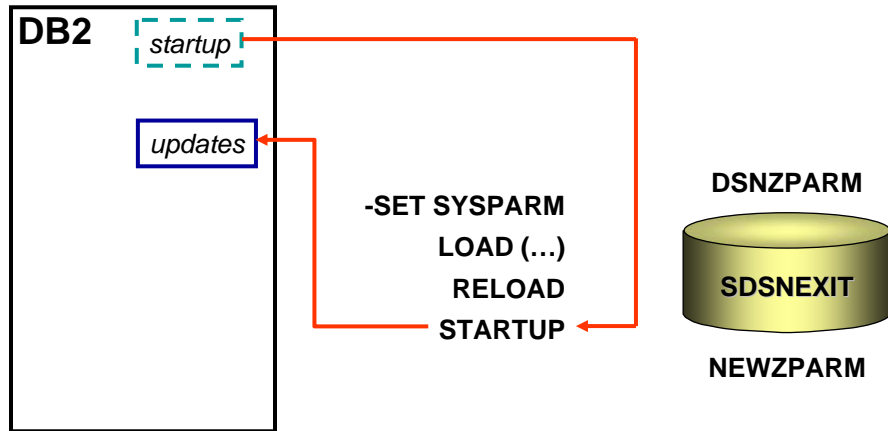

Slide 23 of 80

Copyright © 2005 IBM Corporation
All rights reserved

IBM DB2 Information Management
Technical Conference

Display DSNZPARM Settings

- Sample program DSN8ED7
 - Generates list of current DB2 parameters settings

DSN6SYSP	AUDITST	0000000000	AUDIT TRACE	DSNTIPN	1
DSN6SYSP	CONDBAT	0000000064	MAX REMOTE CONNECTED	DSNTIPE	4
DSN6SYSP	CTHREAD	00030	MAX USERS	DSNTIPE	2
DSN6SYSP	DLDFREQ	00005	LEVELID UPDATE FREQ	DSNTIPL	14
DSN6SYSP	PCLOSEN	00005	SWITCH CHKPTS	DSNTIPL	12

Report
Sample Only

- Calls stored procedure DSNWZP
 - Provided with DB2
 - Also used by Control Center and Visual Explain,
- Sample job DSNTJ6Z prepares and executes DSN8ED7
- Before running DSN8ED7 you must create the stored procedure DSNWZP (installation job DSNTIJSJG).
- Don't forget your other resources that display your ZPARMs

Slide 24 of 80

Copyright © 2005 IBM Corporation
All rights reserved

IBM DB2 Information Management
Technical Conference

What Can You Change

Notes!

- **DSN6ARVP**
 - All parameters are changeable
- **DSN6FAC**
 - RLFERRD, , RESYNC,
- **DSN6LOGP**
 - ARC2FRST, DEALLCT, MAXRTU
- **DSN6GRP**

Slide 25 of 80

Copyright © 2005 IBM Corporation
All rights reserved

IBM DB2 Information Management
Technical Conference

What Can You Change

Notes!

- **DSN6ARVP**
 - All parameters are changeable
- **DSN6FAC**
 - RLFERRD, IDTHTOIN, RESYNC, TCPALVER,
MAXTYPE1, TCPKPALV, POOLINAC
- **DSN6LOGP**
 - ARC2FRST, DEALLCT, MAXRTU
- **DSN6GRP**
 - IMMEDWRI

Underlined parms are
changeable as of Version 8

Slide 26 of 80

Copyright © 2005 IBM Corporation
All rights reserved

IBM DB2 Information Management
Technical Conference

What Can You Change

Notes!

- **DSN6SYSP**

– CHKREQ, CONDBAT,
CTHREAD, DBPROTCL, DLDFREQ, DSSTIME,
, EXTSEC, IDBACK, IDFORE,
IDXBPOOL, IXQTY, LOBVALA, LOBVALS,
MAXDBAT, PCLOSEN, PCLOSET,
PTASKROL, RLFAUTH, RLFERR, RLFTBL,
STATIME, STORMXAB, STORTIME, SYNCVAL,
TBSBPOOL, TSQTY, URCHKTH, URLGWTH,
WLMENV

Slide 27 of 80

Copyright © 2005 IBM Corporation
All rights reserved

IBM DB2 Information Management
Technical Conference

What Can You Change

Notes!

- **DSN6SYSP**

– CHKREQ, CONDBAT,
CTHREAD, DBPROTCL, DLDFREQ, DSSTIME,
EXTRAREQ, **EXTRASRV**, EXTSEC, IDBACK,
IDFORE, IDXBPOOL, IXQTY, LOBVALA, LOBVALS,
MAXDBAT, PCLOSEN, PCLOSET,
PTASKROL, RLFAUTH, RLFERR, RLFTBL,
STATIME, STORMXAB, STORTIME, SYNCVAL,
TBSBPOOL, TSQTY, URCHKTH, URLGWTH,
WLMENV

Slide 28 of 80

Copyright © 2005 IBM Corporation
All rights reserved

IBM DB2 Information Management
Technical Conference

What Can You Change

Notes!

- **DSN6SYSP**

- **ACCUMACC**, **ACCUMUID**, CHKFREQ, CONDBAT, CTHREAD, DBPROTCL, DLDFREQ, DSSTIME, **DSVCI**, EXTRAREQ, EXTRASRV, EXTSEC, IDBACK, IDFORE, IDXBPOOL, IXQTY, LOBVALA, LOBVALS, MAXDBAT, **MGEXTSZ**, PCLOSEN, PCLOSET, PTASKROL, RLFAUTH, RLFERR, RLFTBL, STATIME, STORMXAB, STORTIME, SYNCVAL, TSBPOOL, TSQTY, **UIFCIDS**, URCHKTH, URLGWTH, WLMENV

Parms in RED are new keywords as of Version 8

Slide 29 of 80

Copyright © 2005 IBM Corporation
All rights reserved

IBM DB2 Information Management
Technical Conference

What Can You Change

Notes!

- **DSN6SPRM**

- ABEXP, ABIND, AUTHCACH, BINDNV, BMPTOUT, CDSSRDEF, CONTSTOR, DBACRVW, DESCSTAT, DLITOUT, DSMAX, EDMPOOL, , EVALUNC, IRLMSWT, MAXRBLK, MINRBLK, MINSTOR, NUMLKTS, NUMLKUS, OPTHINTS, PARAMDEG, RECALLD, RELCURHL, RETLWAIT, RRULOCK, SEQCACH, SEQPRES, SJTABLES, SKIPUNCI, SMSDCFL, SMSDCIX, STARJOIN, STATROLL, STATSINT, SUPERRS, SYSADM, SYSADM2, SYSOPR, SYSOPR2, UTIMOUT,

Slide 30 of 80

Copyright © 2005 IBM Corporation
All rights reserved

IBM DB2 Information Management
Technical Conference

What Can You Change

Notes!

- **DSN6SPRM**

- ABEXP, ABIND, AUTHCACH, BINDNV, BMPTOUT, CACHEDYN, CDSSRDEF, CHGDC, CONTSTOR, DBACRVW, DESCSTAT, DLITOUT, DSMAX, EDMBFIT, EDMPOOL, EDPROP, EVALUNC, IRLMSWT, MAXKEEPD, MAXRBLK, MINRBLK, MINSTOR, NPGTHRSH, NUMLKTS, NUMLKUS, OJPERFEH, OPTHINTS, PARAMDEG, PARTKEYU, RECALLD, RELCURHL, RETLWAIT, RETVLCFK, RRULOCK, SEQCACH, SEQPRES, SJTABLES, SKIPUNCI, SMSDCFL, SMSDCIX, SRTPOOL, STARJOIN, STATHIST, STATROLL, STATSINT, SUPERRS, SYSADM, SYSADM2, SYSOPR, SYSOPR2, UTIMOUT, XLKUPDLT

Slide 31 of 80

Copyright © 2005 IBM Corporation
All rights reserved

IBM DB2 Information Management
Technical Conference

What Can You Change

Notes!

- **DSN6SPRM**

- ABEXP, ABIND, **AEXITLIM**, AUTHCACH, BINDNV, BMPTOUT, CACHEDYN, CDSSRDEF, CHGDC, CONTSTOR, DBACRVW, DESCSTAT, DLITOUT, DSMAX, EDMBFIT, **EDMDBDC**, EDMPOOL, **EDMSTMTC**, EDPROP, EVALUNC, IRLMSWT, **LRDRTHLD**, **MAINTYPE**, MAXKEEPD, **MAX_NUM_CUR**, MAXRBLK, **MAX_ST_PROC**, MINRBLK, MINSTOR, NPGTHRSH, NUMLKTS, NUMLKUS, OJPERFEH, OPTHINTS, **PADIX**, PARAMDEG, PARTKEYU, RECALLD, **REFSHAGE**, RELCURHL, RETLWAIT, RETVLCFK, RRULOCK, SEQCACH, SEQPRES, **SJMXPOOL**, SJTABLES, SKIPUNCI, SMSDCFL, SMSDCIX, SRTPOOL, STARJOIN, STATHIST, STATROLL, STATSINT, SUPERRS, SYSADM, SYSADM2, SYSOPR, SYSOPR2, UTIMOUT, **VOLTDEVT**, XLKUPDLT

Slide 32 of 80

Copyright © 2005 IBM Corporation
All rights reserved

IBM DB2 Information Management
Technical Conference

Not Everything Takes Effect Immediately

- AUTHCACH
- LOBVALA
- LOBVALS
- MAXRBLK
- NUMLKTS
- EDMPOOL
- EDMBFIT
- EDMDSPAC (not in V8)
- RLFERRD, RLFAUTH
- RLFTBL, RLFERR
- IDBACK, IDFORE
- BMPTOUT, DLITOUT
- CHKFREQ (was LOGLOAD)
- DEALLCT, MAXRTU
- DSSTIME, STATIME, PCLOSET
- PTASKROL
- MAXDBAT

Slide 33 of 80

Copyright © 2005 IBM Corporation
All rights reserved

IBM DB2 Information Management
Technical Conference

System behavior change

- The following DSNZPARMs may cause a behavioral change when modified.
- PARTKEYU
 - (Restriction to update partitioning key lifted in V5 with APAR PQ16946 and ZPARM added by APAR PQ22653)
 - Changes in Version 8
- SYSADM/SYSADM2
 - (requires Install SYSADM or Install SYSADM2 privilege)
- CACHEDYN & MAXKEEPD
- XLKUPDLT
 - Introduced by APAR PQ18915

Slide 34 of 80

Copyright © 2005 IBM Corporation
All rights reserved

IBM DB2 Information Management
Technical Conference

What's Meant By...

- **Hidden**

- Just what the word implies, they are buried within the macros and not intended to be modified by the general public

- **Opaque**

- Are not available for change using the panels, but.....

- **Visible**

- Changed using the install panels
- Documented in the manuals

Slide 35 of 80

Copyright © 2005 IBM Corporation
All rights reserved

IBM DB2 Information Management
Technical Conference

What's Meant By...

- **Hidden**

- Just what the word implies, they are buried within the macros and not intended to be modified by the general public

- **Opaque**

- Are not available for change using the panels, but.....

- **Visible**

- **OK**, Changed using an editor (but you should use the panels)
- Documented in the manuals

Slide 36 of 80

Copyright © 2005 IBM Corporation
All rights reserved

IBM DB2 Information Management
Technical Conference

Let's Look at the Visible Parameters First

Slide 37 of 80

Copyright © 2005 IBM Corporation
All rights reserved

IBM DB2 Information Management
Technical Conference

Thread Stuff

CONDBAT	DSN6SYSP	DSNTIPE	Max remote connected
CTHREAD	DSN6SYSP	DSNTIPE	Max Users Macro
IDBACK	DSN6SYSP	DSNTIPE	Max batch connect
IDFORE	DSN6SYSP	DSNTIPE	Max TSO connect
MAXDBAT	DSN6SYSP	DSNTIPE	Max remote active

Slide 38 of 80

Copyright © 2005 IBM Corporation
All rights reserved

IBM DB2 Information Management
Technical Conference

Storage

EDMBFIT	DSN6SPRM	DSNTIP8	Free space utilization for large pools
EDMDSPAC (removed in V8)	DSN6SPRM	DSNTIPC	EDM Pool data space size
EDMPOOL	DSN6SPRM	DSNTIPC	environmental descriptor manager pool
SEQCACH	DSN6SPRM	DSNTIPE	Sequential cache
SEQPRES	DSN6SPRM	DSNTIPE	Utility Cache Option
MAXRBLK	DSN6SPRM	DSNTIPC	Storage for RID Blocks
MAXKEEPD	DSN6SPRM	DSNTIPE	Number of dynamic SQL statements that can be keep past a commit point when binding with KEEP DYNAMIC(YES)
SRTPOOL	DSN6SPRM	DSNTIPC	Storage for sort pool
All Threads			See previous foil for list of thread parms

Slide 39 of 80

Copyright © 2005 IBM Corporation
All rights reserved

IBM DB2 Information Management
Technical Conference

Logging

BACKODUR	DSN6SYSP	DSNTIPL	How much back out processing when LBACKOUT
DLDFREQ	DSN6SYSP	DSNTIPL	How often level id is updated in checkpoints
CHKFREQ	DSN6SYSP	DSNTIPL	System checkpoint frequency in minutes or logs
LBACKOUT	DSN6SYSP	DSNTIPL	Should back out log processing be postponed
LOGAPSTG	DSN6SYSP	DSNTIPL	Storage for fast log apply
OUTBUFF	DSN6LOGP	DSNTIPL	Output buffer size used writing the active log
PCLOSEN	DSN6SYSP	DSNTIPL	Duration in checkpoints or minutes between updates before page set is switched to RO
PCLOSET	DSN6SYSP	DSNTIPL	
URCHKTH	DSN6SYSP	DSNTIPL	Number of checkpoint cycles for uncommitted units of recovery (UR)
URLGWTH	DSN6SYSP	DSNTIPL	Number of log records in uncommitted UR

→ SET LOG LOGLOAD/CHKTIME

Slide 40 of 80

Copyright © 2005 IBM Corporation
All rights reserved

IBM DB2 Information Management
Technical Conference

Programming

CACHEDYN	DSN6SPRM	DSNTIP8	Dynamic SQL cache
CDSSRDEF	DSN6SPRM	DSNTIP8	Current degree
DECDIV3	DSN6SPRM	DSNTIP4	Minimum divide scale
DESCSTAT	DSN6SPRM	DSNTIP4	Static describe
OPTHINTS	DSN6SPRM	DSNTIP8	Optimization hints

Slide 41 of 80

Copyright © 2005 IBM Corporation
All rights reserved

IBM DB2 Information Management
Technical Conference

Locking

IRLMRWT	DSN6SPRM	DSNTIPI	Resource timeout
NUMLKTS	DSN6SPRM	DSNTIPJ	Locks per table (space)
NUMLKUS	DSN6SPRM	DSNTIPJ	Locks per user
SKIPUNCI (V8)	DSN6SPRM	DSNTIP8	Skip Uncomm Inserts
EVALUNC	DSN6SPRM	DSNTIP4 (V7) DSNTIP8 (V8)	Evaluate Uncommitted
RRULOCK	DSN6SPRM	DSNTIPI	U LOCK FOR RR/RS
XLKUPDLT	DSN6SPRM	DSNTIPI	X Lock for searched U/D
RELCURHL	DSN6SPRM	DSNTIP4 (V7) DSNTIP8 (V8)	RELEASE LOCKS
RETLWAIT	DSN6SPRM	DSNTIPI	Retained lock timeout

Slide 42 of 80

Copyright © 2005 IBM Corporation
All rights reserved

IBM DB2 Information Management
Technical Conference

Database Access Threads

CMSTAT	DSN6FAC	DSNTIPR	DDF threads
CONDBAT	DSN6SYSP	DSNTIPE	Max remote connected
CONTSTOR	DSN6SPRM	DSNTIPE	Contract thread storage
IDHTOIN	DSN6FAC	DSNTIPR	Idle thread timeout
MAXDBAT	DSN6SYSP	DSNTIPE	Max remote active
POOLINAC	DSN6FAC	DSNTIP5	Pool thread timeout

Slide 43 of 80

Copyright © 2005 IBM Corporation
All rights reserved

IBM DB2 Information Management
Technical Conference

DSMAX

DSMAX	DSN6SPRM	DSNTIPC	Max number of open data sets
Approx Storage used: DSMAX * 1.8K	Default is calculated	Calculated default does not take into account partitioning	Acceptable values: 1 – 100,000 (V8)

Slide 44 of 80

Copyright © 2005 IBM Corporation
All rights reserved

IBM DB2 Information Management
Technical Conference

Deferred Close

Affects CLOSE YES and CLOSE NO page sets

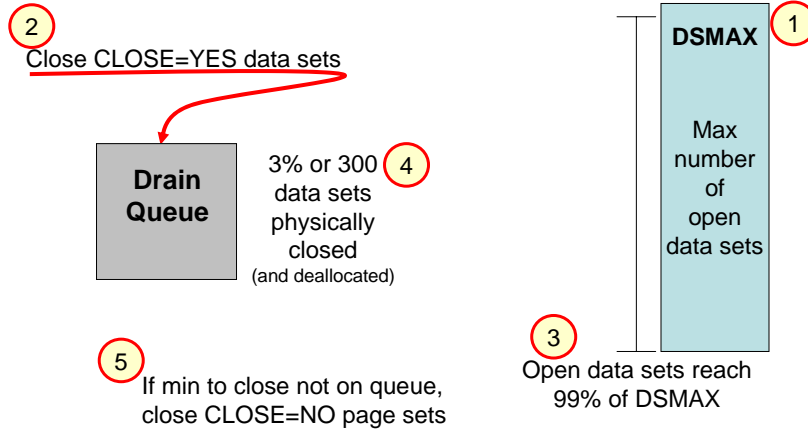

Slide 45 of 80

Copyright © 2005 IBM Corporation
All rights reserved

IBM DB2 Information Management
Technical Conference

Read Only Switch

- RO SWITCH CHKPTS
 - DSN6SYSP PCLOSEN
 - Number of consecutive checkpoints since last update
 - Default is 5 checkpoints
- RO SWITCH TIME
 - DSN6SYSP PCLOSET
 - Number of minutes since last update
 - Default is 10 minutes

Slide 46 of 80

Copyright © 2005 IBM Corporation
All rights reserved

IBM DB2 Information Management
Technical Conference

Read Only Switch

For CLOSE YES and CLOSE NO page sets

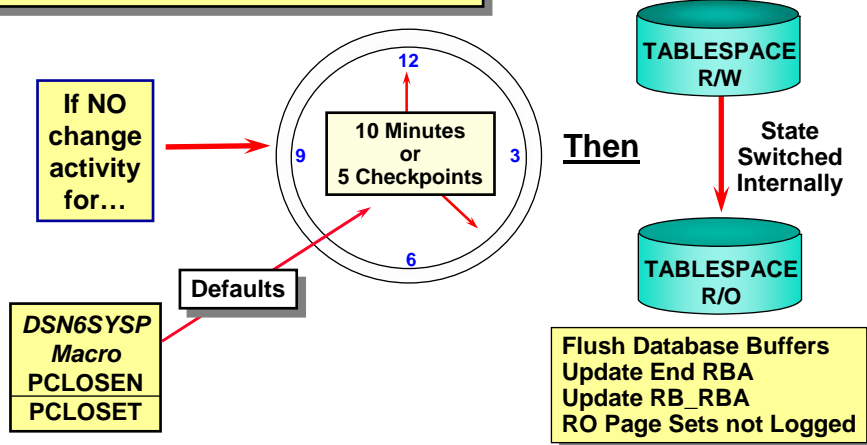

Slide 47 of 80

Copyright © 2005 IBM Corporation
All rights reserved

IBM DB2 Information Management
Technical Conference

DSNZPARAMs Added in Version 8 (1 of 2)

ACCUMACC	DSN6SYSP	DSNTIPN	Specifies whether DB2 accounting data should be accumulated by the user for DDF and RRSF threads.
ACCUMUID	DSN6SYSP	DSNTIPN	Aggregation fields to be used for DDF and RRSF accounting rollup
AEXITLIM	DSN6SPRM	DSNTIPP	AUTH EXIT LIMIT
DSVCI	DSN6SYSP	DSNTIP7	VARY DS CONTROL INTEVAL
EDMDBDC	DSN6SPRM	DSNTIPC	EDM DBD cache size
EDMSTMTC	DSN6SPRM	DSNTIPC	EDM Statement Cache size
LRDRTHLD	DSN6SPRM	DSNTIPE	LONG-RUNNING READER
MAINTYPE	DSN6SPRM	DSNTIP8	Default value for CURRENT MAINTAINED TABLE TYPES FOR OPTIMIZATION special register
MAX_NUM_CUR	DSN6SPRM	DSNTIPX	Maximum number of open cursors

Notes!

Slide 48 of 80

Copyright © 2005 IBM Corporation
All rights reserved

IBM DB2 Information Management
Technical Conference

DSNZPARAMs Added in Version 8 (2 of 2)

Notes!

MAX_ST_PROC	DSN6SPRM	DSNTIPX	Maximum number of stored procedures per thread
MGEXTSZ	DSN6SYSP	DSNTIP7	OPTIMIZE EXTENT SIZING
PADIX	DSN6SPRM	DSNTIPE	Pad new indexes by default
REFSHAGE	DSN6SPRM	DSNTIP8	Default value for the CURRENT REFRESH AGE special register
SJMXPOOL	DSN6SPRM	DSNTIP8	Maximum size of the virtual memory pool for star join queries in MB
SMF89	DSN6SYSP	-----	USAGE PRICING
UIFCIDS	DSN6SYSP	DSNTIPN	Output from IFC records should include Unicode information
VOLTDEVT	DSN6SPRM	DSNTIPA2	Device type or unit name for allocating temporary data sets

Slide 49 of 80

Copyright © 2005 IBM Corporation
All rights reserved

IBM DB2 Information Management
Technical Conference

Changed Online Change Option (1 of 2)

Notes!

			Pre-V8	Version 8	
*	CACHEDYN	DSN6SPRM	DSNTIP8	No	Yes
	CHGDC	DSN6SPRM	DSNTIPO	No	Yes
	EDMBFIT	DSN6SPRM	DSNTIP8	Opaque/No	Yes
	EDPROP	DSN6SPRM	DSNTIPO	No	Yes
	EXTRAREQ	DSN6SYSP	DSNTIP5	No	Yes
	EXTRASRV	DSN6SYSP	DSNTIP5	No	Yes
	IDTHTOIN	DSN6FAC	DSNTIPR	No	Yes
	IMMEDWRI	DSN6GRP	DSNTIP8	No	Yes
	MAXKEEPD	DSN6SPRM	DSNTIPE	No	Yes
	MAXTYPE1	DSN6FAC	DSNTIPR	No	Yes

Slide 50 of 80

Copyright © 2005 IBM Corporation
All rights reserved

IBM DB2 Information Management
Technical Conference

Changed Online Change Option (2 of 2)

			Pre-V8	Version 8
NPGTHRSH	DSN6SPRM	---	Opaque/No	Yes
OJPERFEH	DSN6SPRM	---	Opaque/No	Yes
PARTKEYU	DSN6SPRM	DSNTIP8	Opaque/No	Yes
POOLINAC	DSN6FAC	DSNTIP5	No	Yes
RETVLCFK	DSN6SPRM	DSNTIP8	Yes	Now consider non-padded
SRTPOOL	DSN6SPRM	DSNTIPC	No	Yes
STATHIST	DSN6SPRM	DSNTIPO	No	Yes
TCPALVER	DSN6FAC	DSNTIP5	No	Yes
TCPKPALV	DSN6FAC	DSNTIP5	No	Yes
XLKUPDLT	DSN6SPRM	DSNTIPI	No	Yes

Slide 51 of 80

Copyright © 2005 IBM Corporation
All rights reserved

IBM DB2 Information Management
Technical Conference

DSNZPARAMs Externalized in Version 8...

IXQTY ¹	DSN6SYSP	DSNTIP7	Index space default size
SKIPUNCI ²	DSN6SPRM	DSNTIPS	Skip Uncommitted INSERTs
STARJOIN	DSN6SPRM	DSNTIP8	Enable star join processing
SVOLARC	DSN6ARVP	DSNTIPA	Single volume allocation
TSQTY ¹	DSN6SYSP	DSNTIP7	Table space default size

1 – Available in Version 6 & 7 via APAR PQ53067

2 – Available in Version 7 via APAR PQ79789

The above opaque DSNZPARAMs have externalized through the installation panels in DB2 Version 8.

Slide 52 of 80

Copyright © 2005 IBM Corporation
All rights reserved

IBM DB2 Information Management
Technical Conference

DSNZPARAMs Removed in Version 8...

	COMPAT	DSNHDECP	Serviceability option
	EDMDSPAC	DSN6SPRM	EDM Pool Data Space Size
	EDMDSMAX	DSN6SPRM	EDM Pool Data Space Maximum
→	PKGLDTOL¹	DSN6SPRM	Turn off package requirement for certain SQL statements
	SARGSWRP ²	DSN6SPRM	Allow index access for certain nested correlated table access
→	OPTSUBQ1³	DSN6SPRM	Non-correlated subquery costs
→	OPTCCOS1⁴	DSN6SPRM	List prefetch picked as the access path while regular index access could perform better
→	OPTCCOS2⁵	DSN6SPRM	Inefficient access path or inefficient index is picked for correlated subquery

1 - APAR PQ59207

2 - APAR PQ61024 & PQ66365

3 - APAR PQ50462 & PQ81790

4 - APAR PQ84158

5 - APAR PQ03849 & PQ66335

Slide 53 of 80

Copyright © 2005 IBM Corporation
All rights reserved

IBM DB2 Information Management
Technical Conference

New Version 8 Defaults

	LOBVALA	USER LOB VALUE STORAGE	2048	10240
→	CTHREAD	MAX USERS	70	200
→	MAXDBAT	MAX REMOTE ACTIVE	64	200
→	CONDBAT	MAX REMOTE CONNECTED	64	10000
	IDFORE	MAX TSO CONNECT	40	50
	IDBACK	MAX BATCH CONNECT	20	50
	ACCUMACC	DDF/RRSAF ACCUM	NO	10
→	CACHEDYN	CACHE DYNAMIC SQL	NO	YES
	AUTHCACH	PLAN AUTH CACHE	1024	3072
→	LOGAPSTG	LOG APPLY STORAGE	0	100
→	CHKFREQ	CHECKPOINT FREQ	50000	500000
	BLKSIZE	BLOCK SIZE	28672	24576
→	CMTSTAT	DDF THREADS	ACTIVE	INACTIVE
	IDTHTOIN	IDLE THREAD TIMEOUT	0	120
	EXTSEC	EXTENDED SECURITY	NO	YES
	TCPKPALV	TCP/IP KEEPALIVE	ENABLE	120
→	DSMAX	MAXIMUM OPEN DATA SETS	3000	10000
	EDMPOOL	EDMPOOL STORAGE SIZE	7312	327681

Notes!

Slide 54 of 80

Copyright © 2005 IBM Corporation
All rights reserved

IBM DB2 Information Management
Technical Conference

Added in Version 7

- STATROLL - Statistics Rollup for partitions
- STATSINT – Turn on collecting real time statistics
- MINSTOR - Manage Thread Storage
- OJPERFEH - Disables performance enhancements for outer join operations
- OPTOPSE - Parallelism: Type of sort operations for parallel queries that involve join
- STARJOIN - Fact table cardinality:
 - -1 disabled, 1 fact largest,
 - 0 (25) / n: x largest dimension
- STATHIST - STATISTICS HISTORY, SPACE, NONE, ALL, ACCESSPATH.
 - Default=No

Slide 55 of 80

Copyright © 2005 IBM Corporation
All rights reserved

IBM DB2 Information Management
Technical Conference

Added in Version 7

- CHKFREQ - Checkpoint Freq
 - 200 – 16,000,000 (log records),
 - or 1- 60 (minutes)
 - Default 50,000
- URLGWTH - UR log write check, # of log records written by an uncommitted unit
 - 0 – 1,000K
 - Default 0
 - URCHKTH - UR Checkpoint Frequency can still be used
- SYNCVAL - Monitoring
 - NO / 0-59 - Synchronize among Data Sharing members / Stats & RMF
 - Default NO

Slide 56 of 80

Copyright © 2005 IBM Corporation
All rights reserved

IBM DB2 Information Management
Technical Conference

Added in Version 7

- UGCCSID - Unicode CCSID, Graphics, accept default- data integrity may be compromised.
- UMCCSID - Unicode CCSID, Mixed, accept default- data integrity may be compromised.
- USCCSID - Unicode CCSID, Single, accept default- data integrity may be compromised.
- APPENSCH - Application Encoding Scheme - EBCDIC, if changed release incompatibility

And Then There Was
Opaque 

DISABSCL

- DISABSCL
 - Macro: DSN6SPRM
 - Online Changeable: Yes
 - Default: NO
 - Values: YES/NO
 - Description: Disable scrollable cursor warning messages. If YES is specified and non-scrollable cursors are in use, SQLWARN1 and SQLWARN5 warning messages at OPEN and ALLOCATE CURSOR will be disabled.
 - APAR PQ65622

PTASKROL

- PTASKROL
 - Macro: DSN6SYSP
 - Online Changeable: Yes
 - Default: YES
 - Values: YES/NO
 - Description: Roll up accounting trace records for parallel query task
 - APAR PQ10864

OJPERFEH

- OJPERFEH is used to disable some portion of outer join
 - Macro: DSN6SPRM
 - Online Changeable: Yes
 - Default: YES
 - Values: YES/NO
 - Description: Disable outer join performance enhancements when first release. Now selectively disables certain enhancements
 - APAR PQ18710 – added with default NO
 - APAR PQ48485 – Externalized – Should now be YES

Slide 61 of 80

Copyright © 2005 IBM Corporation
All rights reserved

IBM DB2 Information Management
Technical Conference

SMSDCFL & SMSDCIX

- SMSDCFL - SMS data class name keyword for all table space data sets
- SMSDCIX - SMS data class name keyword for all index space data sets
 - Macro: DSN6SPRM
 - Online Changeable: Yes
 - Default: blank
 - Values: data class name
 - Description: SMS data class name keyword
 - APAR PQ32414

Slide 62 of 80

Copyright © 2005 IBM Corporation
All rights reserved

IBM DB2 Information Management
Technical Conference

NPGTHRSH

- NPGTHRSH
 - Macro: DSN6SPRM
 - Online Changeable: Yes
 - Default: 0
 - Values:
 - Description: Favor index access when tables statistics indicate less than a given number of pages*
- APAR PQ33429

*DB2 Version 8 CREATE/ALTER TABLE option VOLATILE has a similar affect on an access path.
May be a better choice.

UTLRSTR

- UTLRSTR Careful
 - Macro: DSN6SPRM
 - Online Changeable: Yes
 - Default: OFF
 - Values: ON, OFF
 - Description: If set to ON, implicitly restart utility after failure.*
- APAR PQ33429

* Removed in DB2 Version 8

CLAIMDTA

- CLAIMDTA
 - Macro: DSN6SPRM
 - Online Changeable: Yes
 - Default: NO
 - Values: YES, NO
 - Description: If set to YES, the data-first claiming and table space-level claim/drain process is enabled*
 - APAR PQ96628

* Removed in DB2 Version 8

UNION_COLNAME_7

- Macro: DSN6SPRM
- Online Changeable: No
- Default: NO
- Values: NO, YES
- For usability, an optional DB2 system parameter called UNION_COLNAME_7 to the DSN6SPRM macro. YES will cause DB2 Version 8 to behave as Version 7 did.
- APAR: PK03946

And of Course, There are the
Hidden Ones!!! 

Slide 67 of 80

Copyright © 2005 IBM Corporation
All rights reserved

IBM DB2 Information Management
Technical Conference

Hidden DSNZPARMs

Disclaimer #2 and Warning

- All of the following examples are intended to be used for educational purposes ONLY!
- **PROCEED WITH CAUTION!!**
- **BEWARE! WARNING!** Etc. Etc. Etc.
- Danger, danger! Injuries can happen
- Have resume up to date

Danger, Will Robinson! Danger!

Slide 68 of 80

Copyright © 2005 IBM Corporation
All rights reserved

IBM DB2 Information Management
Technical Conference

Hidden DSNZPARMs

OPTNTJP		Stage 1 Null tolerant join predicate PQ39223
Was: SPRMMXTB	Now: MXTBJOIN	Max tables PQ57516
OPTOPSE		Parallelism: Type of sort operations for parallel queries that involve join
SPRMPH		Disable parallelism for short running queries PQ45820, PQ25135
SPRMMQT		Bind cost overhead associated with MQT for short running SQL MQT rewrite threshold – serviceability Default = 120, Set to 0 to turn off rewrite

Slide 69 of 80

Copyright © 2005 IBM Corporation
All rights reserved

IBM DB2 Information Management
Technical Conference

More from Version 8

MAX_OPT_STOR (SPRMMXOS)	Max amount of RDS OP POOL storage consumed by DB2 Optimizer (MB)	20 MB	0 MB – 100 MB
MAX_OPT_CPU (SPRMMXOC)	Max amount of CPU Time consumed by DB2 Optimizer (Seconds)	100 sec	0 sec – 1000 sec
MAX_OPT_ELAP (SPRMMXOE)	Max amount of elapsed time consumed by DB2 Optimizer (Seconds)	100 sec	0 sec – 1000 sec
TABLES_JOINED_THRESH OLD (SPRMTJTH)	The number of tables joined to cause DB2 to limit the amount of resources consumed by Optimizer (V7)	16	0 - 225
MXTBJOIN (SPRMMXTB)	The maximum number of tables that can be joined in a single FROM clause (V7)	225	15 - 225
MXQBCE (SPRMMXCE)	The maximum number of cost entries to be considered for a single FROM clause (V7)	32767	1 - 32767

Slide 70 of 80

Copyright © 2005 IBM Corporation
All rights reserved

IBM DB2 Information Management
Technical Conference

And Yes, Those Hidden Plan Tables

- **SPRMxxxx** - Generates all EXPLAIN data
 - Defaults: 0 = only populate PLAN_TABLE
- Tables updated by BIND or EXPLAIN ALL
 - Similar to EXPLAIN tables in DB2 family
 - Place-holders that need to exist
 - PREDICATE_TABLE
 - REFERENCE_TABLE
 - STRUCTURE_TABLE
 - COST_TABLE
 - PGROUP_TABLE
 - DSN_STATEMENT_TABLE
 - ESTIMATES_TABLE
 - DSN_FUNCTION_TABLE
 - TABSTATS_TABLE
 - COLSTATS_TABLE
 - IDXSTATS_TABLE
 - PLAN_TABLE

Slide 71 of 80

Copyright © 2005 IBM Corporation
All rights reserved

IBM DB2 Information Management
Technical Conference

What Tables are Accessed (examples)

- **STRUCTURE_TABLE** shows execution frequency
 - 1 row per SQL section (QBLOCKNO)
- **REFERENCE_TABLE** shows objects, attributes
 - 1 row per referenced object (table, column, etc.)
- **PREDICATE_TABLE** shows predicate data
 - 1 row per predicate LHS-operator-RHS
 - Shows filter factors, Stage 1-2, indexability
- **COST_TABLE** shows detailed cost estimates
 - 1 row per SQL section step (PLANNO)
 - Composite cost = IFCID 22 MiniPlan cost = QMF statement cost (timerons)

Slide 72 of 80

Copyright © 2005 IBM Corporation
All rights reserved

IBM DB2 Information Management
Technical Conference

You're Right, There's Not Enough

- DDL for hidden EXPLAIN tables
- How do you read tables?
- What can you do with the information?
- Do you REALLY need to know more?

- Probably not.. In fact, you are actually much further ahead just leaving them alone

Slide 73 of 80

Copyright © 2005 IBM Corporation
All rights reserved

IBM DB2 Information Management
Technical Conference

Populate the PLAN_TABLE?

- Explain's output goes three places:
 - PLAN_TABLE
 - Describes access path of SQL statement
 - Help better design SQL statements
 - Can give optimization hints
 - DSN_STATEMENT_TABLE
 - Provides cost estimates
 - Cost in service units and in milliseconds
 - For dynamic and static SQL statements
 - DSN_FUNCTION_TABLE
 - How DB2 resolves functions
 - One row for each function in an SQL statement

Slide 74 of 80

Copyright © 2005 IBM Corporation
All rights reserved

IBM DB2 Information Management
Technical Conference

And Last... But not least...

DSNZPARAM Protection

- As a final, yet very important note, make sure...
- DB2 load libraries are RACF (or equivalent) write protected
- Secure DSNZPARAM source
 - Control who is allowed to modify DSNZPARAM source
- Control who can issue the SET SYSPARM command
 - Only SYSOPR, SYSCTRL, or SYSADM
 - And control who as the above privileges

Session Summary

- Now that you have completed this session, you should be able to:
 - Explain the purpose of DSNZPARM
 - Describe DB2 SET SYSPARM Command
 - Describe each of the macros and their major keywords
 - Describe the different ?type? of DSNZPARMs
 - Advise on how best to use DSNZPARMs

**Thank You
for Attending!
Willie**

*The
End*

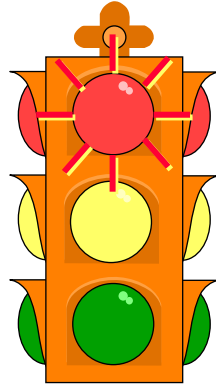

Slide 79 of 80

Copyright © 2005 IBM Corporation
All rights reserved

IBM DB2 Information Management
Technical Conference

*The Good, the Bad, and the Really
Ugly: DSNZPARM
Session: Z51*

William Favero
DB2 Sales Specialist
Western Region
IBM Sales & Distribution
wfavero@attglobal.net

Slide 80 of 80

Copyright © 2005 IBM Corporation
All rights reserved

IBM DB2 Information Management
Technical Conference